

BIL-JAX[®]

36XT



Robert's Diesel Works Inc. (407)246-1597 or (800)341-1307 RDWI@Knuckleboom.com

MADE IN THE
U.S.A.

- **43 ft (13.4 m) working height**
- **32 ft (9.8 m) maximum outreach**
- **Dual Power (DC & Engine)**
- **Automatic leveling**
- **Zero Tailswing**
- **45% Gradeability**

Self-Propelled

High performance 4WD system provides 3.5 mph (5.6 km/h) drive speed and 45% gradeability. Dual power and a narrow machine width makes the 36XT ideal for indoor and outdoor applications.

Lightweight

Low point and floor loading is ideal for applications on lawns, landscaping and sensitive flooring applications. Hydraulic outriggers and automatic leveling capabilities allow users to set up and begin using lift functions in under 30 seconds.

Transportable

With a weight of 5,020 lbs. (2,277 kg) operators can transport the 36XT on a utility trailer attached to a medium-duty SUV or truck. No commercial driver's license required.



X-BOOM[™]

AERIAL WORK PLATFORMS

© Bil-Jax, Inc. 2008

Part No. 0205-0068

Automatic Leveling System

A self-leveling system provides quick and easy set-up in less than 30 seconds.

Hydraulic Outriggers

Optimized outrigger geometry provides industry leading leveling capability.

Working Envelope and Outreach

Telescopic boom design offers exceptional outreach and working envelope.

Easy to Use

Both the platform and ground control station feature an easy-to-understand display panel with control buttons that are logically positioned around a single machine image.

Versatile

A removable platform and optional material lifting system provides the ability to convert the machine into a light duty crane. An integrated 4,500-watt continuous duty generator provides AC power to the 40-amp battery charger and upper and lower GFI outlets for power on the go.

Flexible Power System

The drive system is powered by either four 6-volt 245-amp/hr batteries or the gas engine and the lift system is always powered by batteries for convenient indoor and outdoor use.

Standard Features

- 43 ft (13.4 m) maximum working height
- 32 ft (9.8 m) working outreach
- 500 lb (227 kg) lift capacity
- 3.5 mph (5.6 km/h) maximum drive speed
- 45% gradability
- Outrigger interlocks and tilt alarm/sensor
- Automatic leveling system
- Hydraulic outriggers
- 700-degree non-continuous turntable rotation
- Fully proportional intuitive controls
- Self-leveling platform
- 4,500 watt generator and 110V GFI outlets
- Hour meter and battery condition indicators
- 12½-inch diameter non-marking footpads
- Air line to platform
- Water line to platform

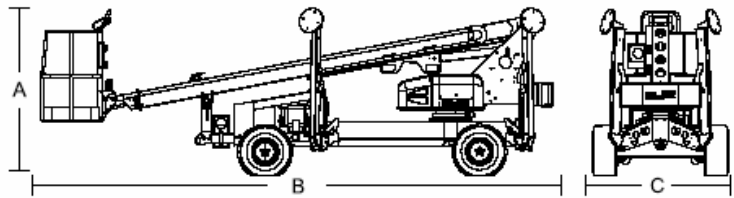

Specifications for 36XT

	US	Metric
Lift height		
Working height ¹	43 ft	13.1 m
Platform height ²	37 ft 6in	11.4 m
Outreach		
Maximum (from centerline)	32 ft	9.8 m
Maximum (from edge of footpad)	27 ft	8.2 m
Turntable rotation	700° non-continuous	
Load capacity	500 lb	227 kg
Leveling capability	12 1/2°	
Stowed dimensions		
(A) Height	6 ft 6 in	1.99 m
(B) Length	20 ft 10 in	6.4 m
(C) Width	5 ft 5 in	1.65 m
Platform dimensions		
Height - railing	43 in	109 cm
Length	30 in	76 cm
Width	60 in	152 cm
Outrigger Footprint		
Length (fully deployed)	12 ft 2 in	3.7 m
Width (fully deployed)	11 ft 3½ in	3.4 m
Footpad diameter	12½ in	32 cm
Outrigger type	Hydraulic w/Auto Leveling	
Power Source	24V DC and 21 HP Kawasaki Gas Engine	
Batteries	4 x 6V 245 amp-hr	
Maximum Speed		
IC power	3.5 mph	5.6 km/h
DC power	1.75 mph	2.8 km/h
Gradability *	45%	
Wheel Base	8 ft 8 in	2.7 m
Turning Radius		
Inside	10 ft	3 m
Outside	17 ft 6 in	5.34 m
Brakes	Spring Applied/Hydraulic Release (Rear Wheels Only)	
Tire Size	26 X 12 bar lug tires	
Total Weight ³	5,020 lbs	2,277 kg

¹ The metric equivalent of working height adds 2 m to the maximum platform height. U.S. adds 6 ft to the maximum platform height.

² Maximum platform height when outriggers are fully extended on a level surface.

³ Weight will vary depending on options and/or market destination; excludes transport trailer weight.

* Dependent on adequate traction.

Options

- Material lifting hook or forks
- Platform tool tray
- Accessory Mounting Trays
- Turf tires
- Non-marking tire (indoors)
- Foam filled tires

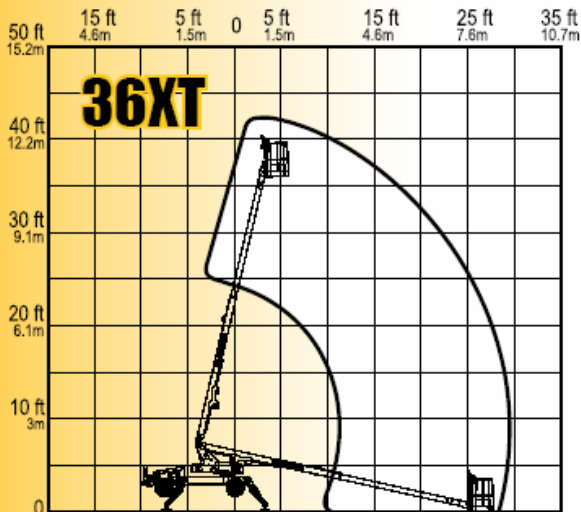

BIL-JAX

Brought to you by:
Robert's Diesel Works Inc.
 407-246-1597 or 800-341-1307